

ELECTRONIC FLUORESCENT LAMP BALLAST

by A. Vitanza, R. Scollo, A. Hayes

1. INTRODUCTION

Fluorescent lamps have applications in most areas of lighting, where they give longer lifetime and lower power consumption for equivalent light output compared to filament bulbs, with the disadvantage of higher initial cost. In operation, a voltage is applied across the ends of a sealed glass tube containing mercury vapour, causing the vapour to be ionised. This ionised vapour radiates light in the ultra violet part of the spectrum, which is converted to visible light by a fluorescent coating on the inside of the tube.

1.1 Driving a fluorescent tube

When the lamp is first turned on, the mains voltage across it is not sufficient to cause the initial ionisation of the vapour. A starting element is thus needed to provide a high voltage pulse across the tube to start the process.

Once the gas in the tube is ionised however, its impedance becomes negative; that is to say the more current that flows through the lamp, the more conductive it becomes (this is because the increased current increases the degree of ionisation of the gas). Therefore, some form of limiter must be added to prevent the current increasing to a level where the lamp is destroyed. The current limiter is usually known as a ballast.

2. CONVENTIONAL LAMP BALLAST

The simplest form of ballast is an inductor. Figure 1 shows a driving circuit for a fluorescent lamp operated from the 220/240V mains.

2.1 The starter

The starter triggers the tube when it is first turned on. It consists of two contact strips, one normal and one bimetallic, which are normally open, enclosed in a glass envelope filled with inert gas. When mains is applied to the circuit, the voltage is not sufficient to cause spontaneous ionisation of the gas in the main tube, and the lamp remains in a high impedance state (i.e. not turned on). However, the electric field which the mains creates in the small gap between

the contacts in the starter is sufficient to ionise the gas there. This allows a current to flow in the metal strips and through the gas (and also through the filaments of the main tube, which heats them and facilitates the subsequent ionisation). The heat generated by the current flow through the gas causes the bimetallic strip to bend towards the other. When the contacts finally touch, two things occur: firstly the gas in the starter de-ionises, and so the bimetallic strip begins to cool. Secondly, as the impedance of the circuit falls, the current through the ballast inductor and the filaments of the main tube increases.

A few tenths of a second later, the bimetallic strip has cooled sufficiently to bend back slightly, reopening the gap. The sudden increase in impedance and consequent sharp reduction in inductor current causes a large overvoltage across the inductor. Given the correct conditions (see section 2.2 below for a discussion of these) this overvoltage is large enough to cause ionisation of the gas in the main tube. At this point the impedance of the fluorescent tube falls to a minimum, and the voltage drop across it falls to a level below that required to ionise the gas in the starter contact gap. The contacts thus remain open until the lamp is next turned on.

Figure 1. Simple conventional lamp ballast

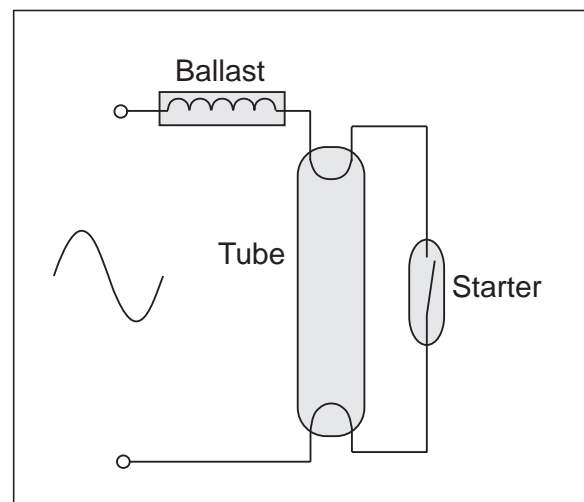

APPLICATION NOTE

2.2 “False starts”

Since there is no synchronisation with the (sinusoidal) mains input, the starter operates at a random time on the current waveform, the contacts opening at an inductor current level anywhere between zero and the maximum. This means the overvoltage generated may not be large enough to cause sustained ionisation of the gas in the tube. If this is the case, the process repeats itself until full ionisation occurs, causing the “flashing” commonly seen at the start up of conventional fluorescent ballasts.

2.3 Problems with conventional ballasts

There are also physical problems with this type of lighting. When the current in the tube falls to zero in each 50/60Hz cycle, the gas in the tube de-ionises and stops emitting light, resulting in a 50/60Hz flicker. This can cause disturbing “stroboscopic” optical effects with moving machinery and VDUs. In industrial plants, fluorescent tubes are used in pairs in a single light spreader, each lamp being fed from different phases, either real or virtual via a capacitor. This helps to eliminate flickering observed by the human eye.

3. ELECTRONIC ALTERNATIVES

Electronic ballasts replace the starting and inductive elements of the conventional system. The aim of using an electronic ballast is to increase the operating frequency of the system above the 50 or 60Hz determined by the mains - typically to a few tens of kHz. This has a two main effects:

- a) The gas in the tube does not have time to de-ionise between current cycles, which leads to lower power consumption (typically about 70% of that with conventional ballast), longer tube life and almost no flicker.
- b) The inductor required to generate a large enough overvoltage to ionise the tube is smaller, and so generates less resistive losses, and the weight of the system is reduced.

However, the electronic solution is more complex and has a higher initial cost - although this will eventually be paid back by the savings in energy.

It should be clear from the section 2 that the electronic replacement for the conventional ballast should perform two main functions: first to provide the start-up ionisation energy, and secondly to provide a constant RMS supply to the tube in normal operation.

The most commonly used electronic drive circuits for fluorescent lamps are voltage fed half-bridge

quasi-resonant circuits (figure 2), current fed half-bridge resonant circuits (figure 5), and push-pull resonant circuits (figure 8).

3.1 Voltage fed quasi-resonant circuit.

The simplicity and low cost of this topology means that this configuration is the only option for Compact Fluorescent Lamp (CFL) ballasts (those used as direct replacements for incandescent bulbs) in the 7W to 32W range. It is also used in large (industrial) ballasts driving two or more full-sized tubes, but requires additional protection circuits in this case.

3.1.1 Starting the oscillation

Resistor R1, capacitor C2 and diac D2 form the first base current pulse for TR2 to start the oscillation. After start-up, this generator is made inoperative by diode D1 (this diode prevents the voltage across the diac from becoming high enough to bias the device on), and the circuit is maintained in oscillation by feedback to the gates of the transistors from the output circuit via the transformer T1.

The tube is fed by generating an overvoltage across capacitor C4, by means of the series resonant circuit consisting of the serial combination of the inductor L and capacitors C3 and C4. Before the tube is started, as C4 is much smaller than C3, C4 dominates the resonant frequency of this circuit. Depending on the value at which the tube lights, the overvoltage generated across C4 at this frequency is between around 600V and 1.2kV.

3.1.2 Steady-state operation

Once the tube ionised, as there is effectively a short circuit across C4, the operating frequency is defined by C3 only, and so is lower. At this frequency the overvoltage generated is also lower - just sufficient to keep the tube lit.

In normal operation, when the transistor is first turned on, the current through transformer T1 increases until its core saturates. At this point the feedback to the base of the transistor is removed, and after the storage time of the transistors has passed, it turns off. In this way, apart from the value of C3, the operating frequency of the circuit is also defined by the size and maximum flux density of the core of T1, and the storage times of the transistors. This frequency is generally designed to be slightly higher than the natural resonance frequency of the circuit.

As the circuit is operating at slightly higher than its resonant frequency, the combined reactance of C3

Figure 2. Voltage fed half-bridge quasi-resonant lamp ballast (startup circuit shown shaded grey)

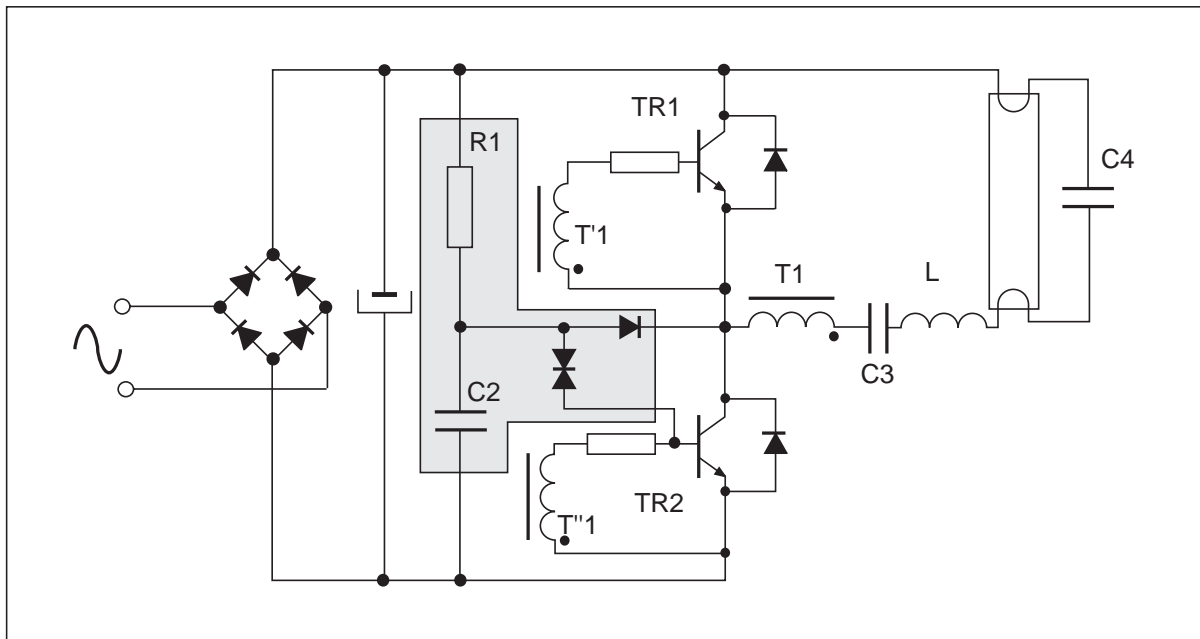
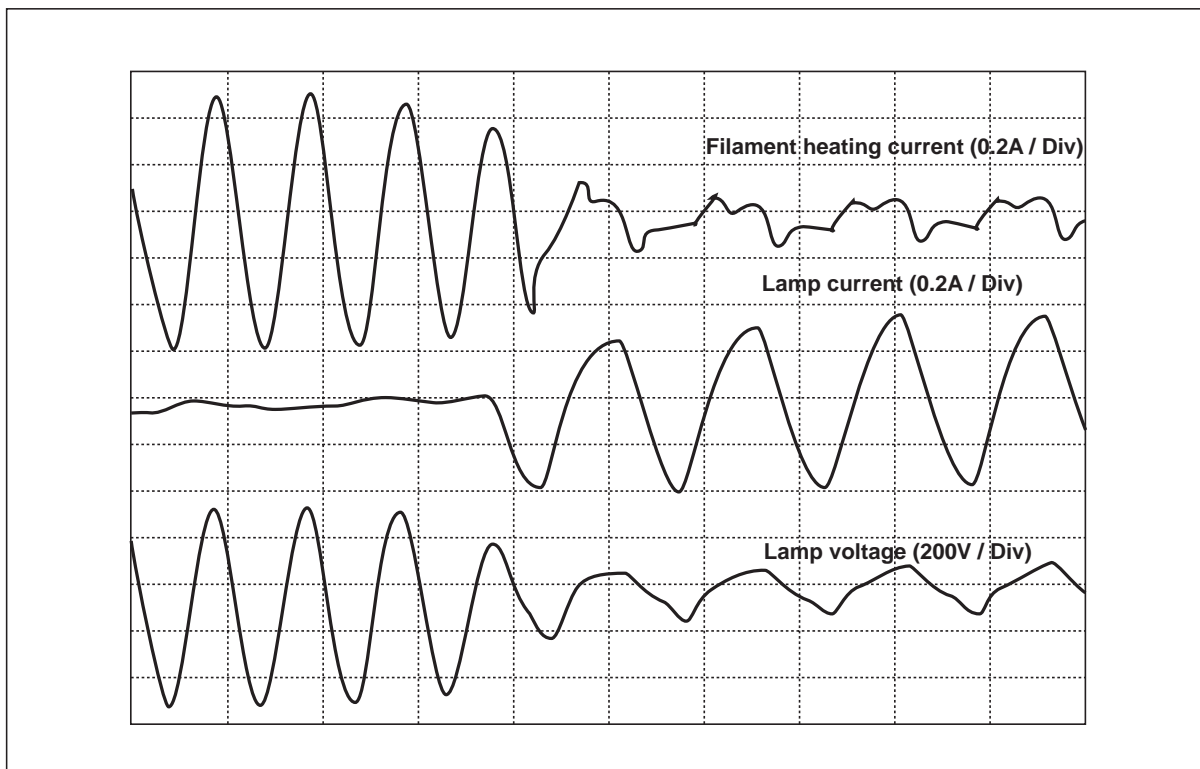

Figure 3. Start-up of the voltage fed ballast



and L is not zero - hence the V_{CE} voltage of the transistors is shared between the tube and the capacitor/inductor combination.

At start-up, the voltage across capacitor $C4$ causes more or less instantaneous ionisation of the fluorescent tube - there are no "false starts" as there

APPLICATION NOTE

are with conventional ballasts. Figure 3 shows the voltage and current in the lamp at start-up. The peak collector current at start-up is around 3 - 5 times the normal operating current, and so it is necessary to select transistors with ratings to withstand this: in the resonant condition the current in the network is limited only by the DC resistance.

Waveforms for the circuit in the steady state are shown in figure 4.

3.1.3 Slow-starting or damaged lamps

Although the circuit can withstand being turned on with no lamp connected (as it will not resonate), a great deal of stress is placed upon it if for some reason the lamp will not start correctly (for example if the gas has leaked out), or if the lamp is too slow to start. This is because the transistors can only stand the high levels of current at start-up for a short period of time, before they overheat and are destroyed.

This problem does not exist for the other topologies, as even in the start-up phase the level of current is not excessive.

3.2 Current fed resonant circuits

3.2.1 Starting the oscillation

The start-up circuit operates in the same way as in

the voltage fed topology. The high voltage to strike the tube comes from the action of the output transformer - before the lamp is struck, the transformer sees an open load, and so the voltage it generates is higher than in normal operation.

Note that the circuit shown has no filament pre-heating - however it would be possible to add circuits such as those described later for the push-pull topology. The lack of pre-heating means that in this case the tubes will strike at a higher voltage.

3.2.2 Steady-state operation

Once the lamps are struck the voltage generated by the output transformer falls, as it sees them as a resistive load.

The circuit oscillates due to the resonance of C_3 , C_R and the inductance of T1. The primary and secondary of T2 are coupled such that one transistor connects the positive part of the wave, and the other the negative. Base drive for the transistors is provided by feedback windings of the output transformer.

Waveforms for the circuit in the steady-state are shown in figure 6, while figure 7 shows the worst-case conditions which the transistors must be designed to withstand; start-up with a supply voltage

Figure 4. Steady state waveforms of the voltage source ballast

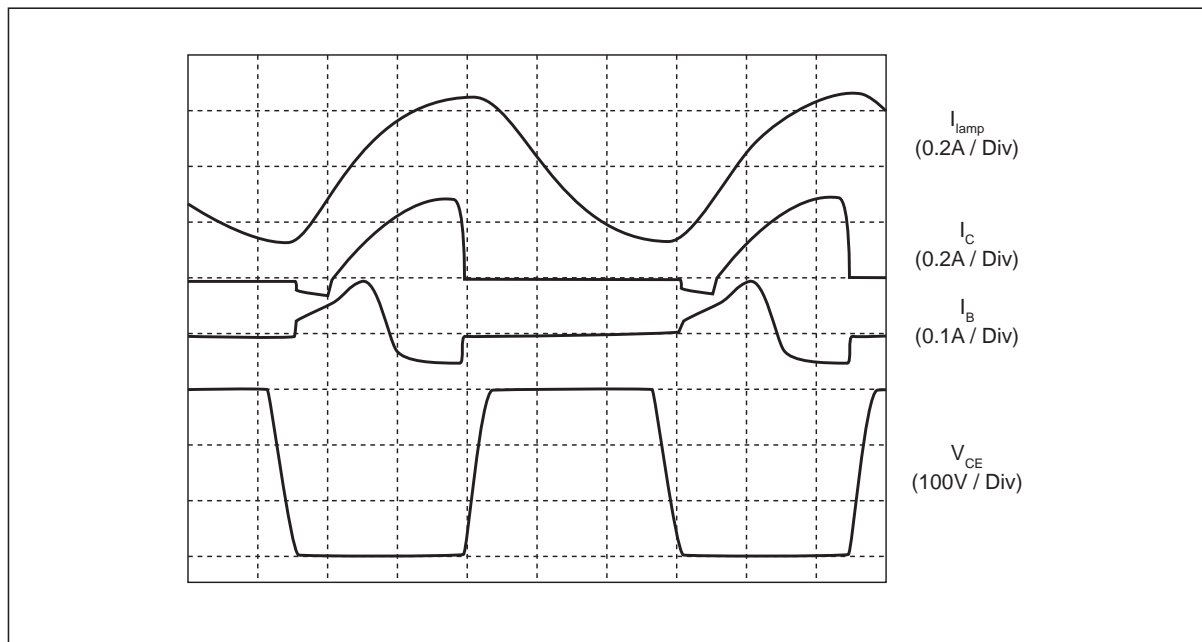

20V above the nominal value of 120V RMS and no lamp connected in a), and "arcing" testing of the ballast during installation in b). Figure 7a shows that the V_{CE} of the transistor can reach around 600V,

while figure 7b shows that a device with a large safe operating area is required, as large voltages and currents exist simultaneously.

Figure 5. Current fed half bridge resonant lamp ballast (start-up circuit shown shaded grey)

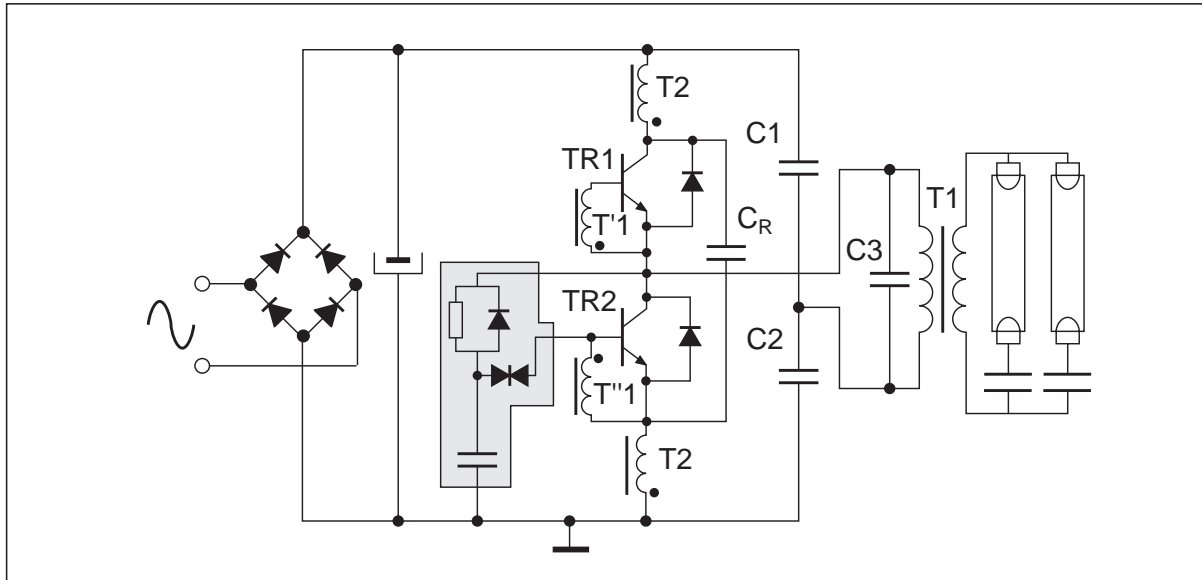
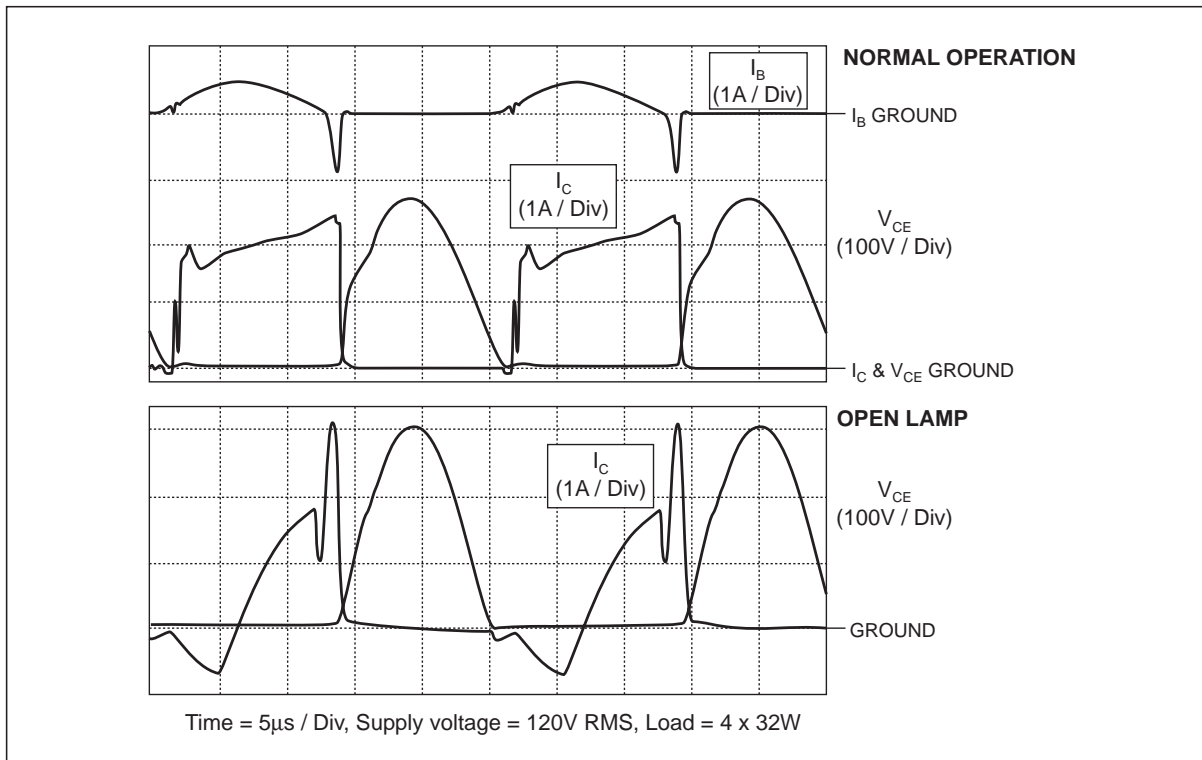

Figure 6. Steady state waveforms of the current fed ballast



APPLICATION NOTE

Figure 7. Worst-case operating conditions for the current-fed ballast circuit:

- Start-up with open load
- Transient which may occur during "arcing test"

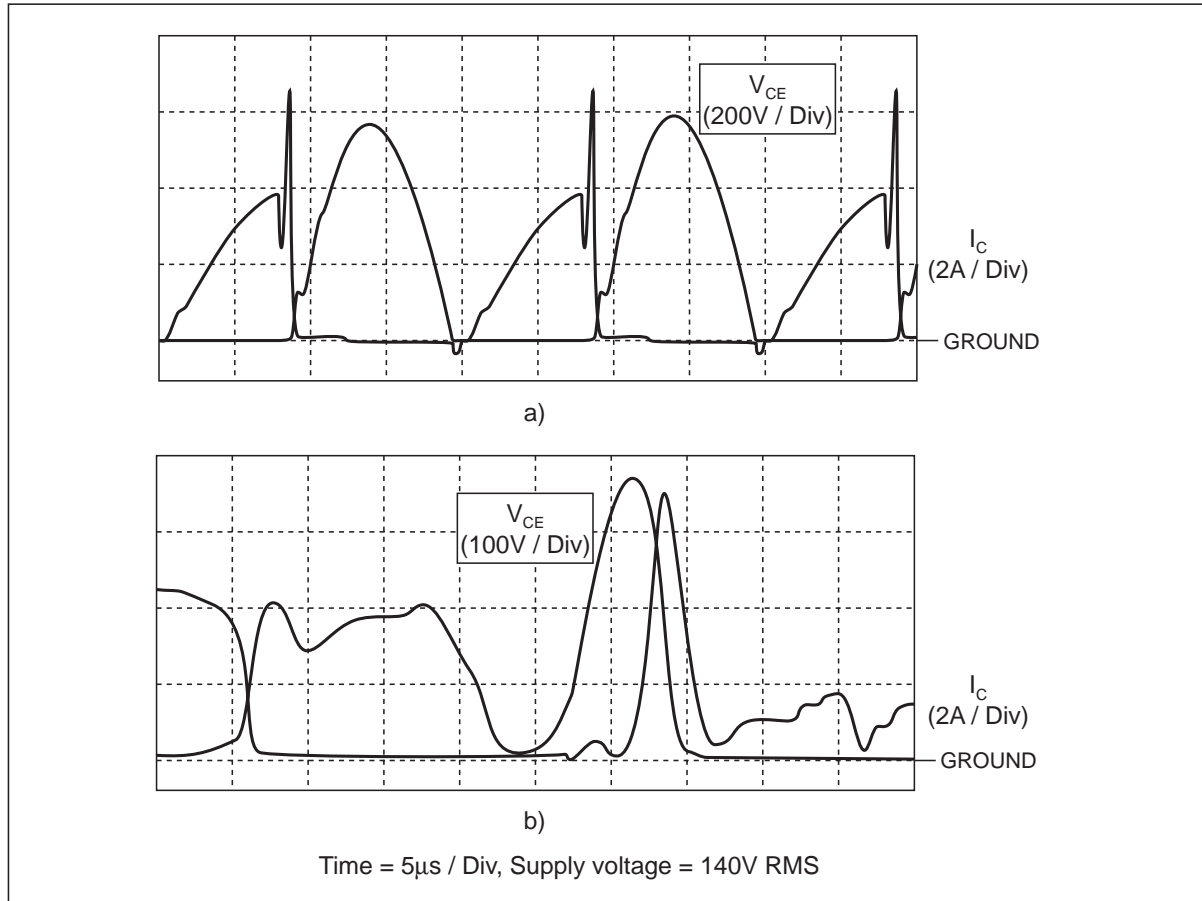

3.3 Push-pull resonant circuits.

This topology has a main advantage in that it can tolerate open or short circuited loads indefinitely. It is generally used in large ballasts. It generates an almost perfectly sinusoidal voltage through the lamp, each transistor producing half of the sin wave.

3.3.1 Starting the oscillation

The circuit oscillates due to the capacitor C1, and the inductance of the transformer. The inductor L acts as a constant current source, maintaining the resonant circuit in oscillation by feeding energy into it to compensate for that absorbed by the load.

The oscillation is triggered by the high-value resistor R1, which pulls up the base-emitter voltage of the transistors. Once the oscillation has started, and before the lamp is ionised, the windings S1 and S2 generate a current to heat the lamp filaments, while

S3 generates the high voltage required to ionise the lamp (the voltage it generates is high as it is effectively connected across an open load).

3.3.2 Steady-state operation

Once the lamp is ionised, S2 provides the drive for the lamp. As the impedance of the lamp has fallen, the voltage across S2 is much smaller in this situation than in start-up. The voltage across S1 and S3, and consequently the filament currents, also reduce.

Base drive for the transistors is provided by means of feedback windings from the output transformer.

Waveforms for the circuit in the steady-state are shown in figure 9. The collector-current spikes at each switching event are caused by both transistors conducting simultaneously - one in the forward direction, and the other in the reverse, through the collector-base diode.

Figure 8. Push-pull resonant ballast

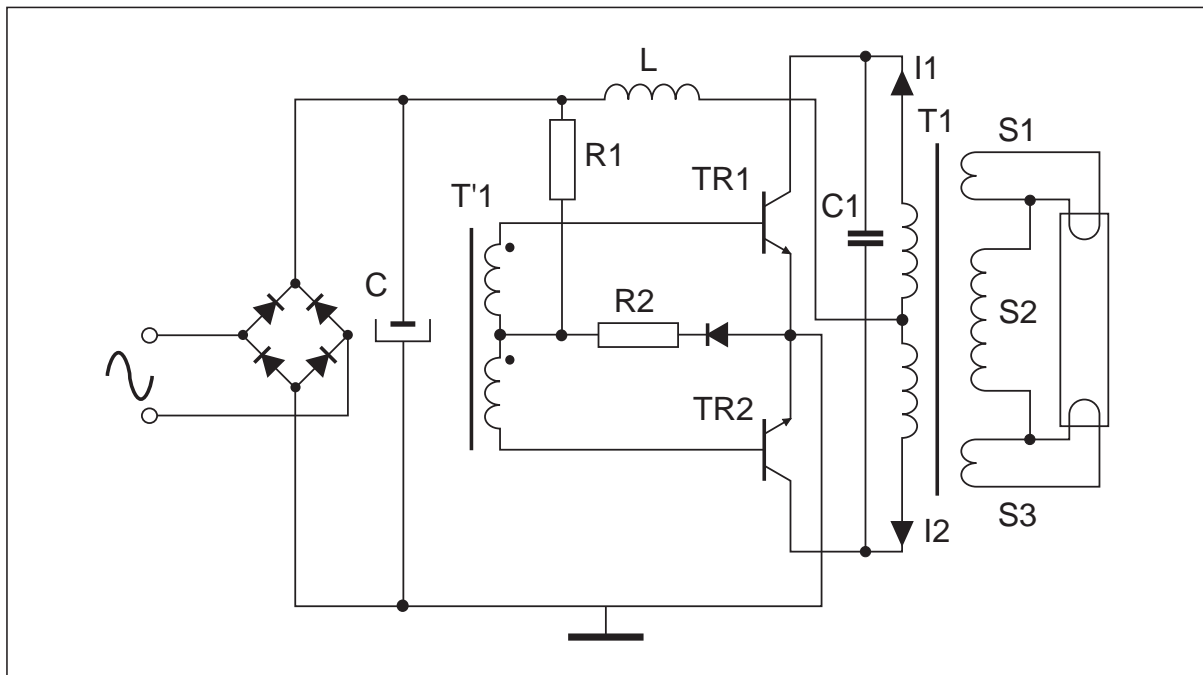
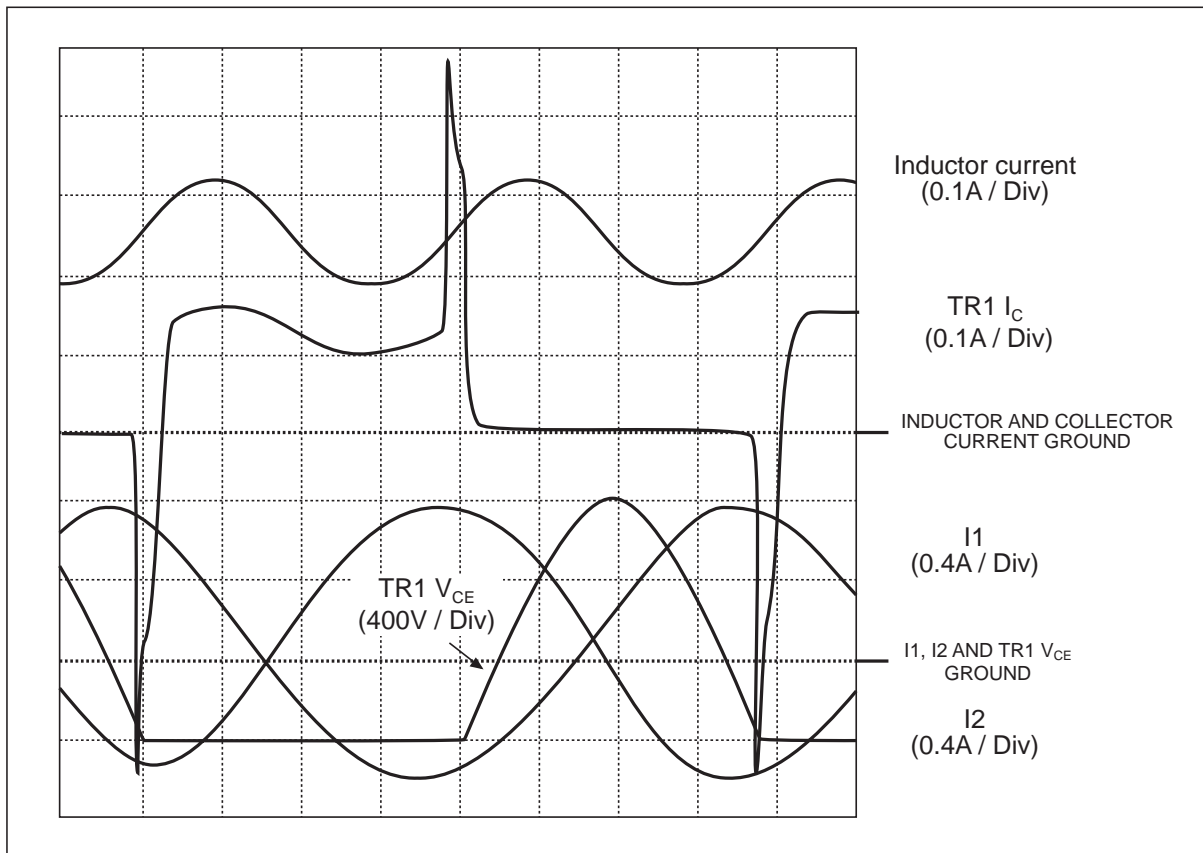

Figure 9. Steady state waveforms of the push-pull ballast



APPLICATION NOTE

3.4 Problems with electronic ballasts

3.4.1 Dimming

The most common technique used in dimming in general is phase control (feeding only a part of the supply sinewave to the lamp). However, this will lead to problems of flicker in electronic lamp ballasts.

The lamp could feasibly be dimmed by controlling the oscillation frequency of the circuit (and hence the voltage drop on the inductor), although there are problems with this. The basic circuit oscillates at a frequency affected by a large number of factors, not at a fixed, known frequency determined by the designer. If the frequency is to be controlled, the circuit must be designed to operate within certain limits to avoid inefficient operation and possible malfunction of the devices. This means a much greater design effort and a much more complex and costly circuit. For this reason dimming circuits are not often included in electronic ballasts.

3.4.2 Power factor and EMI reduction

Because it operates at a higher frequency than the mains, an electronic ballast will transmit EMI back to the supply. Also, most ballasts draw a non-sinewave current from the mains - that is they do not have a unity power factor - unlike an incandescent bulb. To satisfy the requirements of the power supply companies requires the addition of some form of power factor correction (PFC). For a low power application, a simple passive filter will be sufficient, but high power ballasts will require an active power factor corrector circuit.

4. SELECTION OF TRANSISTORS

4.1 Choosing between MOSFETs and Bipolars

In many cases, there can be very little to choose between a Power MOSFET and a Power Bipolar in an application. In general terms, the Power Bipolar is fractionally cheaper, and is currently the most popular choice for this reason. However, the Power MOSFET does not have the problems associated with variations in storage time (see section 4.5 below) and so no special selections have to be carried out. The performance is also more predictable and varies less between circuits, particularly the frequency of oscillation - this can be extremely important in applications requiring power factor correction and the limiting of EMI interference, as the frequency emissions of the circuit will be much more predictable and testable.

4.2 Selecting the blocking voltage of the transistors

4.2.1 Voltage-fed topology

The peak voltage across the transistors is equal to the peak mains voltage, plus a 15% allowance for mains voltage variation, plus a 10% safety margin.

For example, for the 220V RMS mains:

$$\begin{aligned}\text{Peak voltage} &= (220\text{V} \times \sqrt{2}) + 15\% + 10\% \\ &= 394\text{V}\end{aligned}$$

It would seem that devices with a BV_{CES} of 400V could be used - however this would mean that the devices would have a BV_{CEO} less than the voltage applied by the mains, which is not advisable. Hence the transistors should have a BV_{CEO} rating of 400V minimum.

The same type of calculation can be used for other supply voltages:

Supply voltage	120V	220V	277V
BV_{CEO}	300V	400V	4~500V

4.2.2 Current-fed topology

As can be seen in the waveforms in figure 7, the peak voltage experienced by a transistor in a 120V system in worst-case operation is around 600V. The presence of transients due to the inductances and capacitances of the circuit means that in practice and additional safety margin is added, and devices of around 800V are used.

Supply voltage	120V	220V	277V
BV_{CES}	7~900V	900~1kV	1.2~1.3kV

4.2.3 Push-pull topology

The peak voltage across the transistors in the steady state is equal to twice the peak mains voltage, due to reflection from the transformer:

$$V_{\text{peak}} = 2 \times \sqrt{2} \times V_{\text{mains}}$$

For the 220V mains, this gives a value of around 620V. In practice a safety margin is added to protect the device from transients at turn-on and turn-off, leading to the use of devices rated at around 1400.

Supply voltage	120V	220V	277V
BV_{CES}	800~1kV	1.3~1.5kV	1.6kV

4.3 Current ratings

The calculation of the current rating of the transistors used varies considerably depending on the topology, power rating etc. Table1 shows approximate values.

Table1. Approximate working collector current values for lamp ballast topologies

Topology	Power	120V	220V	277V
Voltage fed (CFL)	17~32W	0.4~0.8A	0.3~0.6A	-
Voltage fed (Industrial)	36~132W	1~4A	0.5~2A	0.5~2A
Current fed	36~132W	1~2.5A	0.5~1.5A	0.5~1.5A
Push-Pull	36~132W	1~2A	0.6~1.2A	0.5~1A

4.4 Storage times

When Bipolar transistors are used, the operating frequency of the generator is heavily dependent on the storage time of the transistors. This parameter can affect the operation of the circuit in two main ways:

- If the storage time of the transistors is high, the oscillation frequency of the circuit will fall, causing the voltage across the lamp to increase, in turn possibly damaging them. This effect is most important in the voltage-fed topology (see section 3.1.2).
- If the storage times of the pair of transistors are too dissimilar, one transistor will generate more switching losses, causing it to heat up more, and possibly causing the device to go into thermal runaway.

The SGS-THOMSON BULxxx series of power bipolar transistors produced for electronic lamp ballast applications is characterised specifically by storage times to meet this criterion.

4.5 D.C. gain (h_{FE})

In all topologies, this must be sufficiently high at the start-up levels of current levels (around five times the nominal) to ensure that the circuit starts correctly at all temperatures. Additionally, the transistors in a push-pull topology must also have a sufficiently high gain at very low current levels to start up the ballast, as this topology relies on startup by "noise" (rather than the forced startup by diac as used in the other topologies).

5. CONCLUSIONS

Electronic ballast can be used to replace both the starting element and the conventional ballast of fluorescent lamps.

Although they are more complex and costly than their electromagnetic counterparts, they offer increased light output efficiency, reduced weight, and a removal of the problems of flicker. All this is achieved by increasing the frequency at which the tube is driven above the 50Hz defined by the mains frequency. The higher initial cost of the system will eventually be compensated for by the reduction in energy consumed.

APPLICATION NOTE

Information furnished is believed to be accurate and reliable. However, STMicroelectronics assumes no responsibility for the consequences of use of such information nor for any infringement of patents or other rights of third parties which may result from its use. No license is granted by implication or otherwise under any patent or patent rights of STMicroelectronics. Specification mentioned in this publication are subject to change without notice. This publication supersedes and replaces all information previously supplied. STMicroelectronics products are not authorized for use as critical components in life support devices or systems without express written approval of STMicroelectronics.

The ST logo is a trademark of STMicroelectronics

© 1999 STMicroelectronics - Printed in Italy - All Rights Reserved

STMicroelectronics GROUP OF COMPANIES

Australia - Brazil - China - Finland - France - Germany - Hong Kong - India - Italy - Japan - Malaysia - Malta - Morocco -
Singapore - Spain - Sweden - Switzerland - United Kingdom - U.S.A.

<http://www.st.com>